

# 320kW<sup>1</sup> Packaged Industrial Chiller

## AWA SEA 2270 ZC



### FEATURES:

Compliant with EcoDesign EER Lot 21 (Tier 2) 2021 (ERP21) European energy efficiency regulations.

Air cooled packaged glycol chiller designed for industrial process cooling, including:

Highly energy efficient, low noise, dual hermetic scroll compressors

Refrigerant - R410a

Electronic expansion valve

Integral high pressure 3.5 Bar dual pumpset

Integral pressurised/closed loop buffer tank

Suitable for outdoor siting

Three phase power supply

### Specification Overview<sup>7</sup>

Model	AWA SEA 2270 ZC
Cooling Duty	319 kW <sup>2</sup> / 169 kW <sup>3</sup>
Settable Temperature Range	-4°C to +15°C
Refrigerant / Refrigerant Charge	R410a / 26 kg
Fluid	Water/Glycol 30%
Fluid Flow Rate <sup>4</sup>	58,000 <sup>2</sup> / 30,510 <sup>3</sup> Litres/Hour
Internal Pump Maximum Pressure	3.5 Bar <sup>4</sup>
Internal Pressurised Tank Capacity	150 Litres
Connection Sizes	3" Victaulic
Power	400V/3Ph/50Hz
Full Load Amps	263.2 Amps <sup>5</sup>
Full Load Power	94.7 kW <sup>2</sup> / 83.2 kW <sup>3</sup>
Dimensions (mm)	2,357 (H) x 2,477 (L) x 2,002 (W)
Net Weight	2,055 Kg <sup>6</sup>
Suitable for Outdoor Siting	Fully Weatherproof

<sup>1</sup> Nominal Performance - See Data, Page 5

<sup>2</sup> 15°C / 20°C Fluid, 30°C Ambient, 30% Glycol

<sup>3</sup> -4°C / +1°C Fluid, 30°C Ambient, 30% Glycol

<sup>4</sup> Run & Standby Pumps with Optional Inverter Drive.  
Pump Performance Graph, Page 4

<sup>5</sup> Maximum Starting Current: 260 Amps

<sup>6</sup> Including Packaging and Refrigerant, Tank Empty

<sup>7</sup> Due to the continuous development of our products, all information is subject to change without notice.  
Data Sheet V1.0

# 320kW Packaged Industrial Chiller

## AWA SEA 2270 ZC

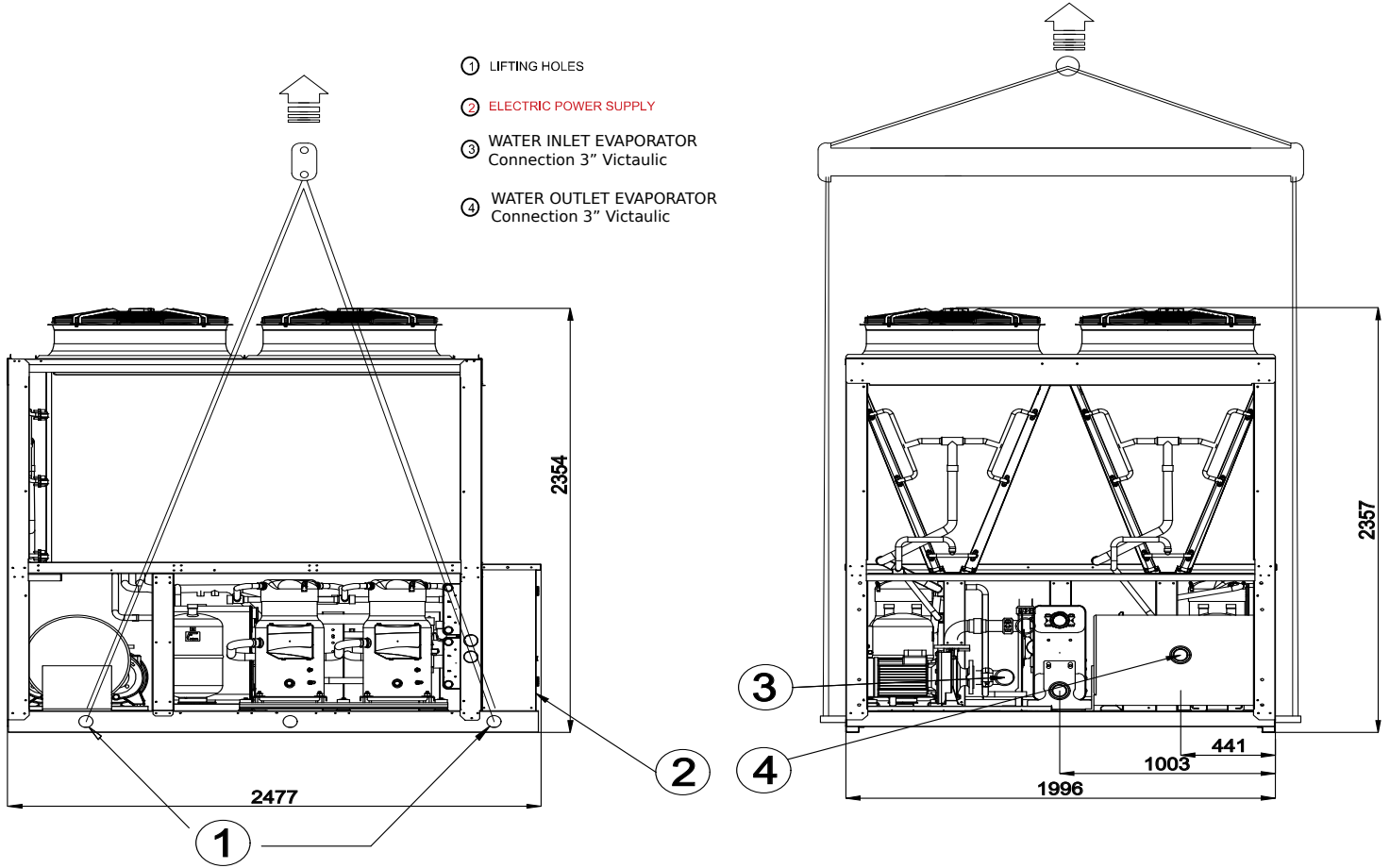

NOTE  
 The position of the hydraulic connection is indicative and may differ from as-built

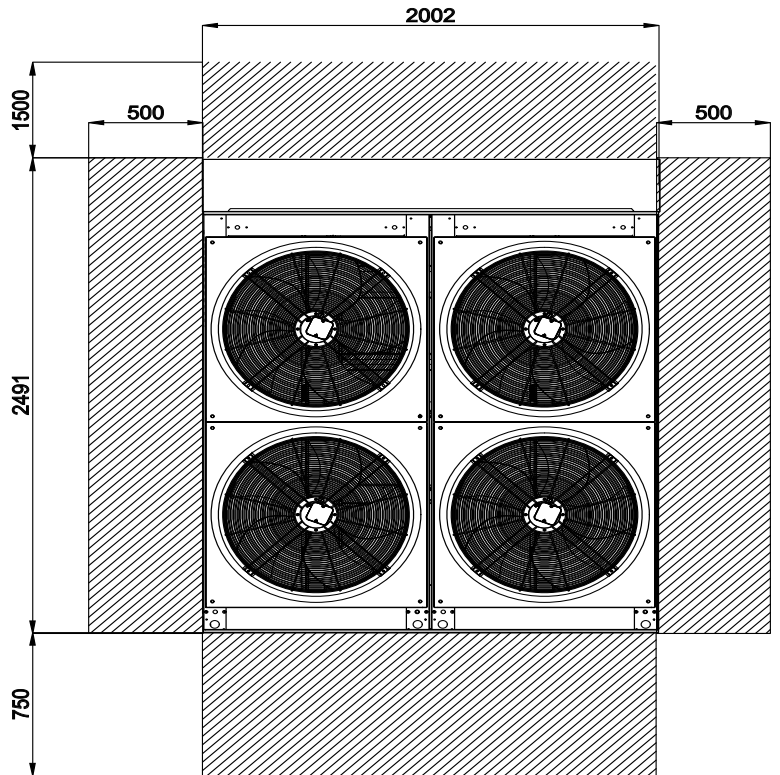
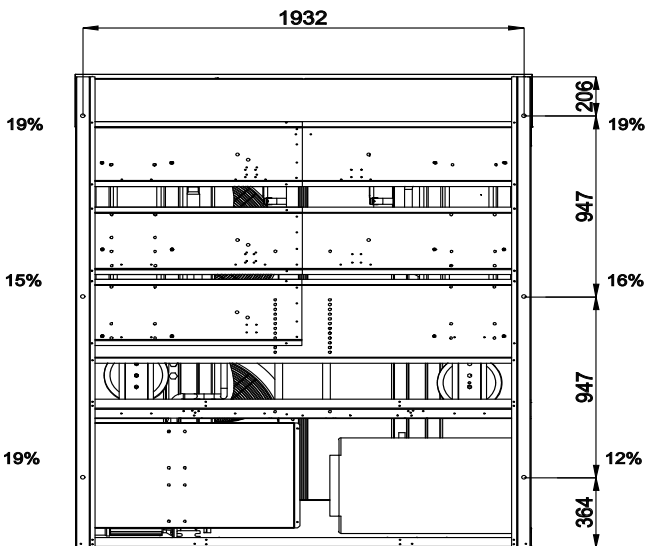

### GENERAL DESCRIPTION

The AWA SEA 2270 is an efficient, reliable and versatile air cooled glycol chiller, intended for cooling industrial processes in a pressurised closed loop system. Compliant with ERP 2021 energy efficiency regulations, the unit has 4 hermetic scroll compressors, 2 refrigerant circuits, microchannel condenser coils, 4 axial fans and is designed for outdoor installation.

### FRAME

The casing is made with heavy gauge galvanized steel. The powder coated anti-corrosive treatment over the entire frame provides long lasting resistance for outdoor installation, even in aggressive environmental conditions.

### REFRIGERANT CIRCUIT

The two independent R410a based refrigerant circuits are constructed entirely with copper tubing. Each circuit includes an electronic expansion valve, filter dryer, sight glass, liquid line solenoid valve and shut-off valve, high and low pressure switches and a relief valve on the high pressure line.

### COMPRESSORS

The unit is equipped with Four hermetic, direct-drive, 3000 rpm 50 Hz scroll compressors with Intermediate Discharge Valves (IDVs). The IDV adapts the energy consumption to the varying load and pressure conditions in the system.

### ELECTRONIC EXPANSION VALVES

The electronic expansion valves minimise the time taken to react to load variations, and optimise the superheat to the evaporator to ensure the best possible energy efficiency. They are managed by a PID controller, with min/max operating pressure control.

### CONDENSER

The air-cooled condenser uses microchannel coils with aluminum fins. This provides a number of significant benefits:

- It reduces the refrigerant charge by up to 37% compared with a conventional Al-Cu condenser.
- The heat transfer surface is greatly increased, so these heat exchangers provide higher performance and are more compact than conventional tube & fin condensers.
- Significant weight reduction which reduces cost, maintenance time and CO<sub>2</sub> transport emissions.
- Made entirely of 100% recyclable aluminum, to fully respect and protect the environment.

Optional anti-corrosion coatings are available to protect the coils if required.

### EVAPORATOR

Direct expansion, stainless steel AISI 316 brazed plate heat exchanger, externally insulated with closed cell anticondensation material and equipped with water differential pressure switch and antifreeze protection electric heater.

### FANS

The four electronically commutated (EC) Class F, IP55 condenser fans use motors equipped with variable speed control, permanently lubricated ball bearings and external overload protection.

### INTEGRAL PUMPS AND TANK

Includes two high capacity, 3.5 bar water pumps, shut off valves, check valves and drain valves.

The 150 litre water tank includes safety, relief and drain valves together with an expansion vessel. It is made from black steel sheet, finishing with anti-corrosion treatment and painting. The thermal and condensation insulation is protected by a water and scratch-resistant external coating. Tanks are individually pressure tested to 9 bar to guarantee a working pressure up to 3,5 bar.

### RUBBER VIBRATION DAMPERS

These are placed between the unit base and the support structure to prevent the transmission of vibration and noise.

# 320kW Packaged Industrial Chiller

## AWA SEA 2270 ZC



### ELECTRICAL PANEL

The electrical control panel is compliant with CEI 44-5/IEC 204-2, is mounted inside the unit and includes:

- Safety locked main switch.
- Fuses and contactors for compressors and fans.
- Fuses for 220V and 24V auxiliary circuits.
- Transformer for 24Vac auxiliary circuit power supply.
- Low voltage user terminals board.

The unit is equipped with FG7 cables, selected for their superior resistance to UV exposure.

### MICROPROCESSOR

The AWA SEA 2270 is controlled by a 256 bit programmable microcontroller with a low reflection LCD user interface equipped with eight function keys and display icons. The microcontroller controls the water temperature, antifreeze protection, compressor timing, compressor automatic starting sequence, alarm reset, alarms and operation LEDs.

It can be connected with a Building Management System (MBS) via an integrated RS485/Modbus interface. It also provides an interface with I/O expansion modules via CanBus, can be controlled by voltage free contacts and supports Ethernet RJ45 for remote control of the unit. A USB port enables upload of parameter files, system files and firmware, and download of alarm history and parameter files.

### CONTROL AND PROTECTION

The microcontroller protects numerous features of the unit including, low evaporating pressure/high condensing pressure, high temperature of the compressor, pump and fan motor windings, reverse rotation for each compressor, insufficient water flow, evaporator outlet water temperature too low or inlet water temperature too high and low pressure difference between discharge and suction (to ensure correct compressor lubrication).

### SOUND LEVELS

Sound Level	63 Hz	125 Hz	250 Hz	500 Hz	1 kHz	2 kHz	4 kHz	8 kHz		
Lw dB	100	96	91	87	84	82	76	71	Lw total dBa	90
Lp dB	68	64	59	55	52	50	44	39	Lp total dBa	58

### OPERATING RANGE

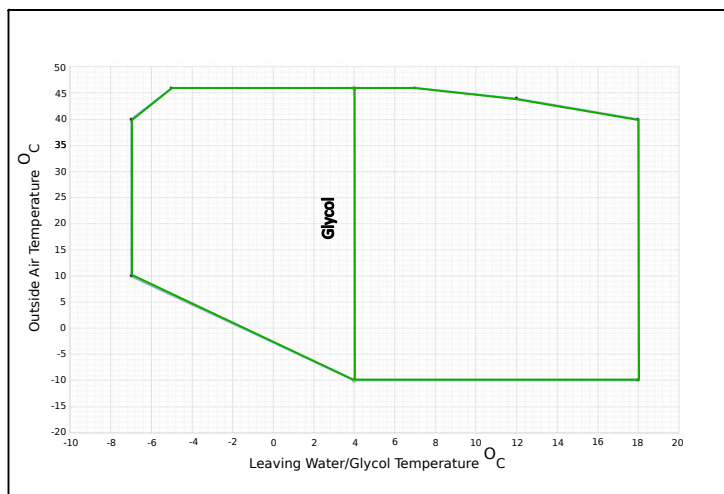

### PUMP CURVE

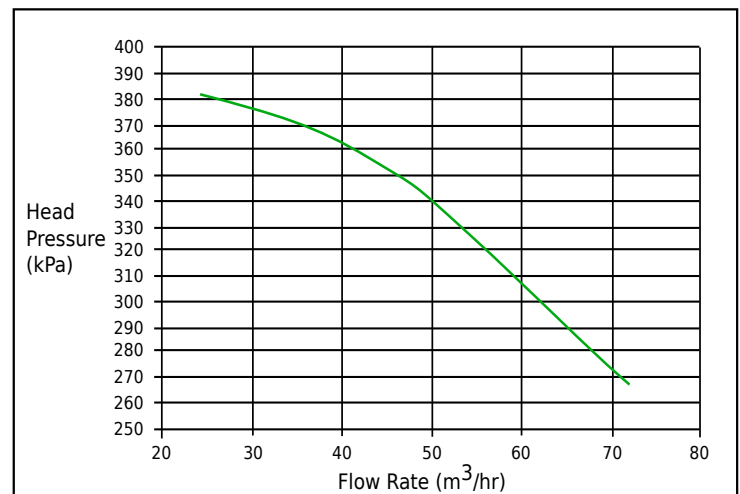

### Glycol Cooling Performance Multiplier

Percentage Glycol	F <sub>g</sub>	%	0	5	10	15	20	25	30	35	40
		Factor	1.03	1.03	1.02	1.02	1.01	1.01	1.01	1	0.99

### AWA SEA 2270 Cooling Power kW

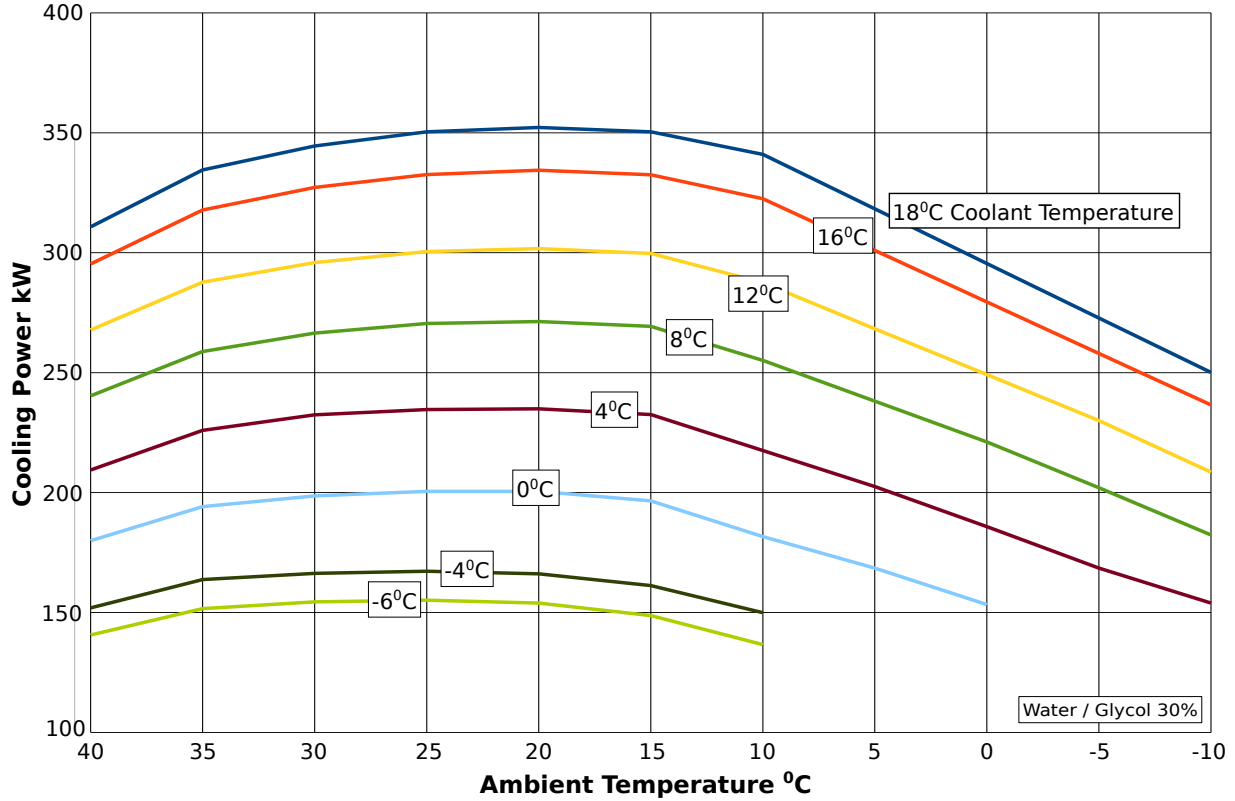

### AWA SEA 2270 Energy Efficiency Rating (EER)

