

95kW¹ Packaged Industrial Glycol Chiller

Domino SEA 177 ZC



FEATURES:

Fully Compliant with EcoDesign EER Lot 21 (Tier 2) 2021 (ERP21) European energy efficiency regulations.

Air cooled packaged glycol chiller designed for industrial process cooling, including:

Highly energy efficient, low noise, dual hermetic scroll compressors

Refrigerant - R410a

Electronic expansion valve

Integral high pressure 3.5 Bar dual pumpset

Integral pressurised/closed loop buffer tank

Suitable for outdoor siting

Three phase power supply

Specification Overview⁷

Model	Domino SEA 177 ZC
Cooling Duty	94.5 kW ² / 49.4 kW ³
Settable Temperature Range	-4°C to +15°C
Refrigerant / Refrigerant Charge	R410a / 8 kg
Fluid	Water/Glycol 30%
Fluid Flow Rate ⁴	17,160 ² / 8,920 ³ Litres/Hour
Internal Pump Maximum Pressure	3.5 Bar ⁴
Internal Pressurised Tank Capacity	120 Litres
Connection Sizes	2" Victaulic
Power	400V/3Ph/50Hz
Full Load Amps	77 Amps ⁵
Full Load Power	26.3 kW ² / 23.6 kW ³
Dimensions (mm)	2,354 (H) x 2,979 (L) x 1,004 (W)
Net Weight	639 Kg ⁶
Suitable for Outdoor Siting	Fully Weatherproof

¹ Nominal Performance - See Data, Page 5

² 15°C / 20°C Fluid, 30°C Ambient, 30% Glycol

³ -4°C / +1°C Fluid, 30°C Ambient, 30% Glycol

⁴ Run & Standby Pumps with Optional Inverter Drive.
Pump Performance Graph, Page 4

⁵ Maximum Starting Current: 197 Amps

⁶ Including Packaging and Refrigerant, Tank Empty

⁷ Due to the continuous development of our products, all information is subject to change without notice.
Data Sheet V1.11

95kW Packaged Industrial Glycol Chiller

Domino SEA 177 ZC



Dimensions

- ① Lifting Holes
- ② Electric Power Supply Input
- ③ Water Inlet (Evaporator) - 2" Victaulic Indicative Position Only
- ④ Water Outlet (Evaporator) - 2" Victaulic Indicative Position Only
- ⑤ Loading Points

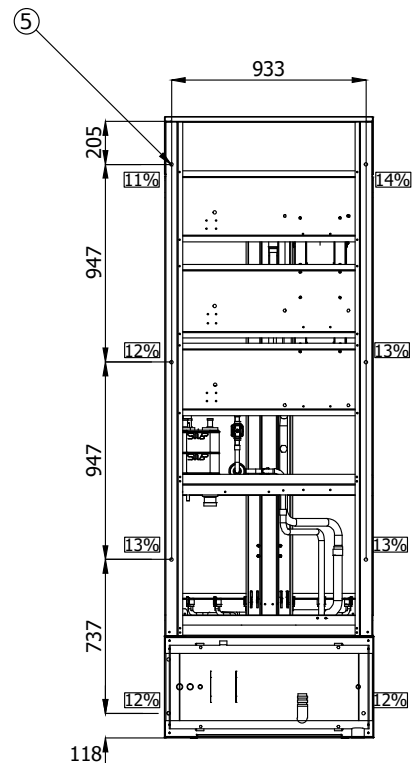
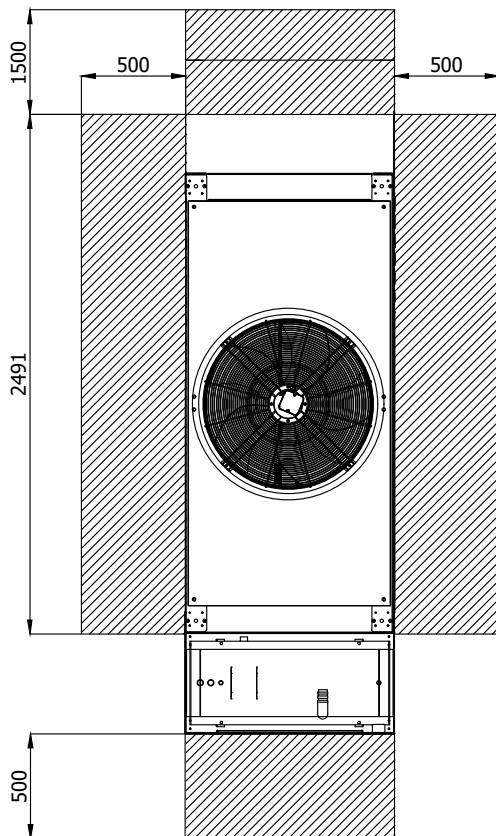
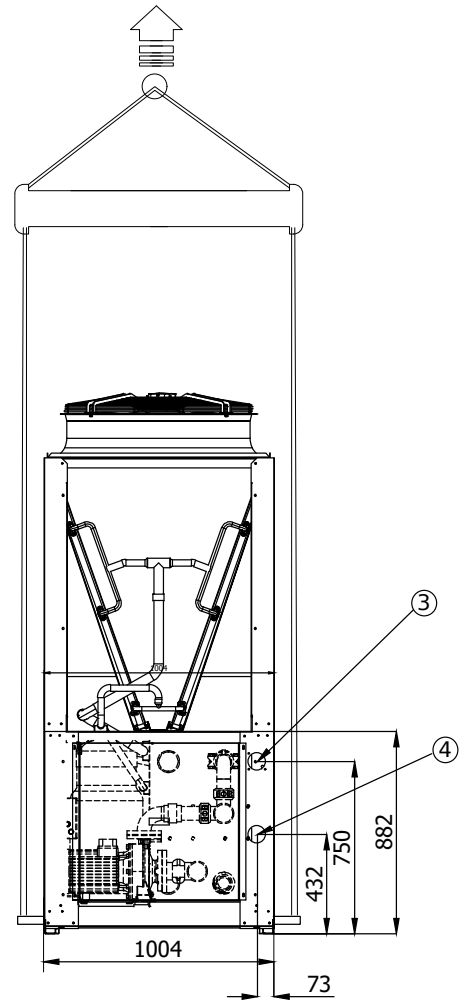
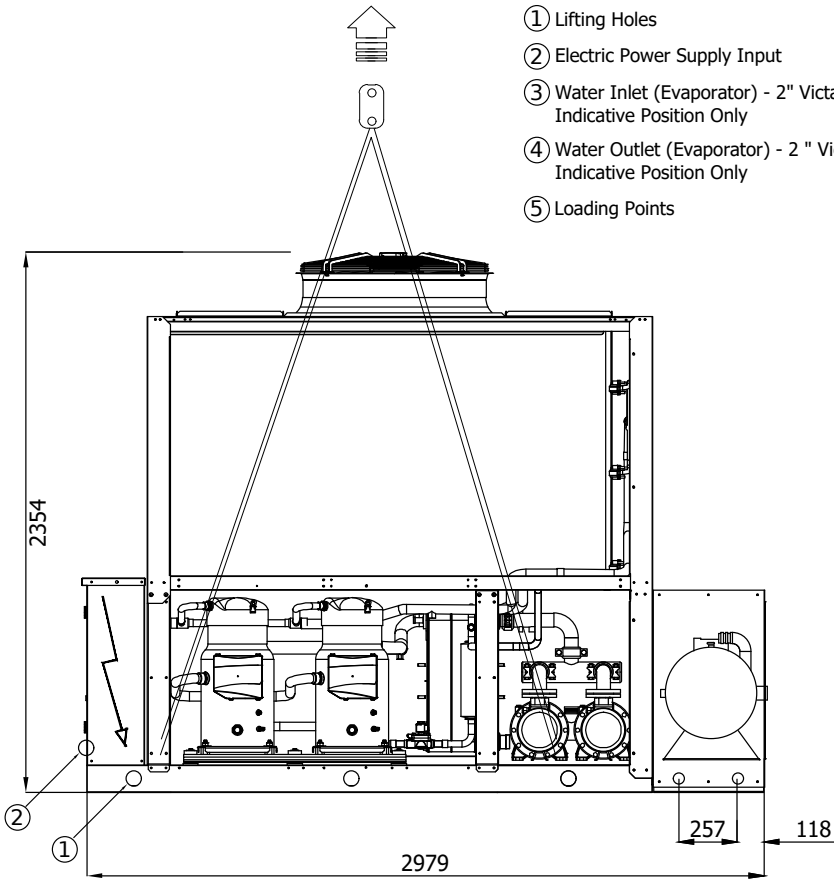

GENERAL DESCRIPTION

The Domino SEA 177 is an efficient, reliable and versatile air cooled glycol chiller, intended for industrial process cooling in a pressurised closed loop system. Compliant with ECODESIGN ENER LOT21 - Tier 2 (2021) European energy efficiency regulations (ERP21), the unit has two hermetic scroll compressors, microchannel condenser coils, one EC (Electronically Commutated) axial fan and is designed for outdoor installation.

FRAME

The casing is made with heavy gauge galvanized steel. The powder coated anti-corrosive treatment over the entire frame provides long lasting resistance for outdoor installation, even in aggressive environmental conditions.

REFRIGERANT CIRCUIT

The R410a based refrigerant circuit is constructed entirely with copper tubing. It includes an electronic expansion valve, filter dryer, sight glass, liquid line solenoid valve and shut-off valve, high and low pressure switches and a relief valve on the high pressure line.

COMPRESSORS

The unit is equipped with two hermetic scroll compressors.

ELECTRONIC EXPANSION VALVE

The electronic expansion valve minimises the time taken to react to load variations, and optimises the superheat to the evaporator to ensure the best possible energy efficiency.

CONDENSER

The air-cooled condenser uses microchannel coils with aluminum fins. This provides a number of significant benefits:

- It reduces the refrigerant charge by up to 37% compared with a conventional Al-Cu condenser.
- The heat transfer surface is greatly increased, so these heat exchangers provide higher performance and are more compact than conventional tube & fin condensers.
- Significant weight reduction which reduces cost, maintenance time and CO₂ transport emissions.
- Made entirely of 100% recyclable aluminum, to fully respect and protect the environment.

Optional anti-corrosion coatings are available to protect the coils if required.

EVAPORATOR

Direct expansion, stainless steel AISI 316 brazed plate heat exchanger, externally insulated with closed cell anticondensation material and equipped with water differential pressure switch and antifreeze protection electric heater.

FAN

The electronically commutated (EC) Class F, IP55 condenser fan uses motors equipped with variable speed control, permanently lubricated ball bearings and external overload protection.

INTEGRAL PUMPS AND TANK

Includes two high capacity water pumps, shut off valves, check valves and drain valves.

The 120 litre water tank includes safety, relief and drain valves together with an expansion vessel. It is made from black steel sheet, finishing with anti-corrosion treatment and painting. The thermal and condensation insulation is protected by a water and scratch-resistant external coating. Tanks are individually pressure tested to 9 bar to guarantee a working pressure up to 3,5 bar.

RUBBER VIBRATION DAMPERS

These are placed between the unit base and the support structure to prevent the transmission of vibration and noise.

95kW Packaged Industrial Glycol Chiller

Domino SEA 177 ZC



ELECTRICAL PANEL

The electrical control panel is compliant with CEI EN 60204-1 (CEI44-5: CEI EN 62061), is mounted inside the unit and includes:

- Safety locked main switch.
- Fuses and contactors for compressors and fans.
- Fuses for 220V and 24V auxiliary circuits.
- Transformer for auxiliary circuit power supply.
- Start up contactors for compressors, pumps and fans

The unit is equipped with numbered cables, designed for operation up to 55°C

MICROPROCESSOR

The Domino SEA 177 is controlled by a 256 bit programmable microcontroller with a low reflection LCD user interface equipped with eight function keys and display icons. The microcontroller controls the water temperature, antifreeze protection, compressor timing, compressor automatic starting sequence, alarm reset, alarms and operation LEDs.

It can be connected with a Building Management System (MBS) via an integrated RS485/Modbus interface. It also provides an interface with I/O expansion modules via CanBus, can be controlled by voltage free contacts and supports Ethernet RJ45 for remote control of the unit. A USB port enables upload of parameter files, system files and firmware, and download of alarm history and parameter files.

CONTROL AND PROTECTION

The microcontroller protects numerous features of the unit including, low evaporating pressure/high condensing pressure, high temperature of the compressor, pump and fan motor windings, reverse rotation for each compressor, insufficient water flow, evaporator outlet water temperature too low or inlet water temperature too high and low pressure difference between discharge and suction (to ensure correct compressor lubrication).

SOUND LEVELS

Sound Level	63 Hz	125 Hz	250 Hz	500 Hz	1 kHz	2 kHz	4 kHz	8 kHz		
Lw dB	92	88	84	80	77	75	69	64	Lw total dBA	83
Lp dB	60	56	52	48	45	43	37	32	Lp total dBA	51

OPERATING RANGE

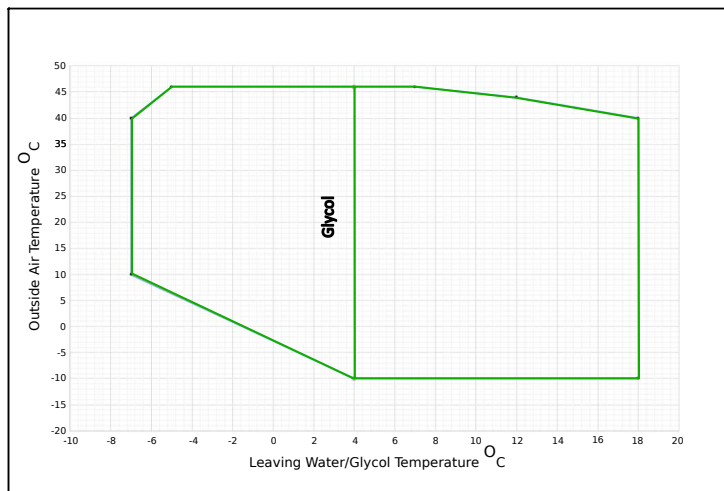

PUMP CURVE

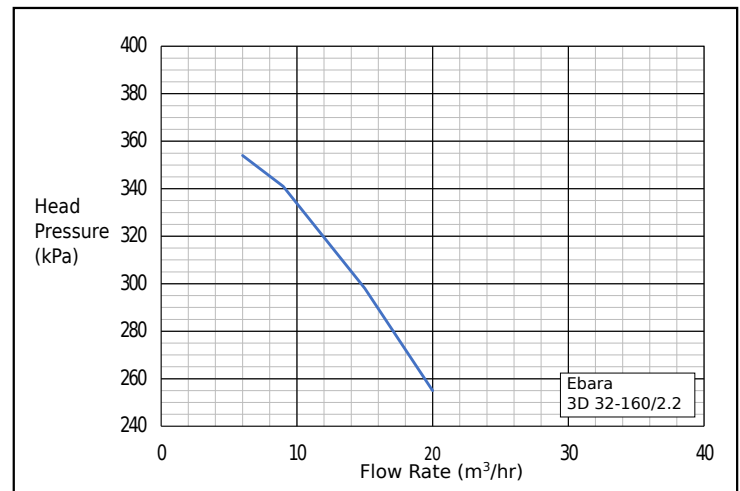

Glycol Cooling Performance Multiplier

Percentage Glycol	F _g	%	0	5	10	15	20	25	30	35	40
		Factor	1.03	1.03	1.02	1.02	1.01	1.01	1.01	1	0.99

Domino SEA 177 Cooling Power kW

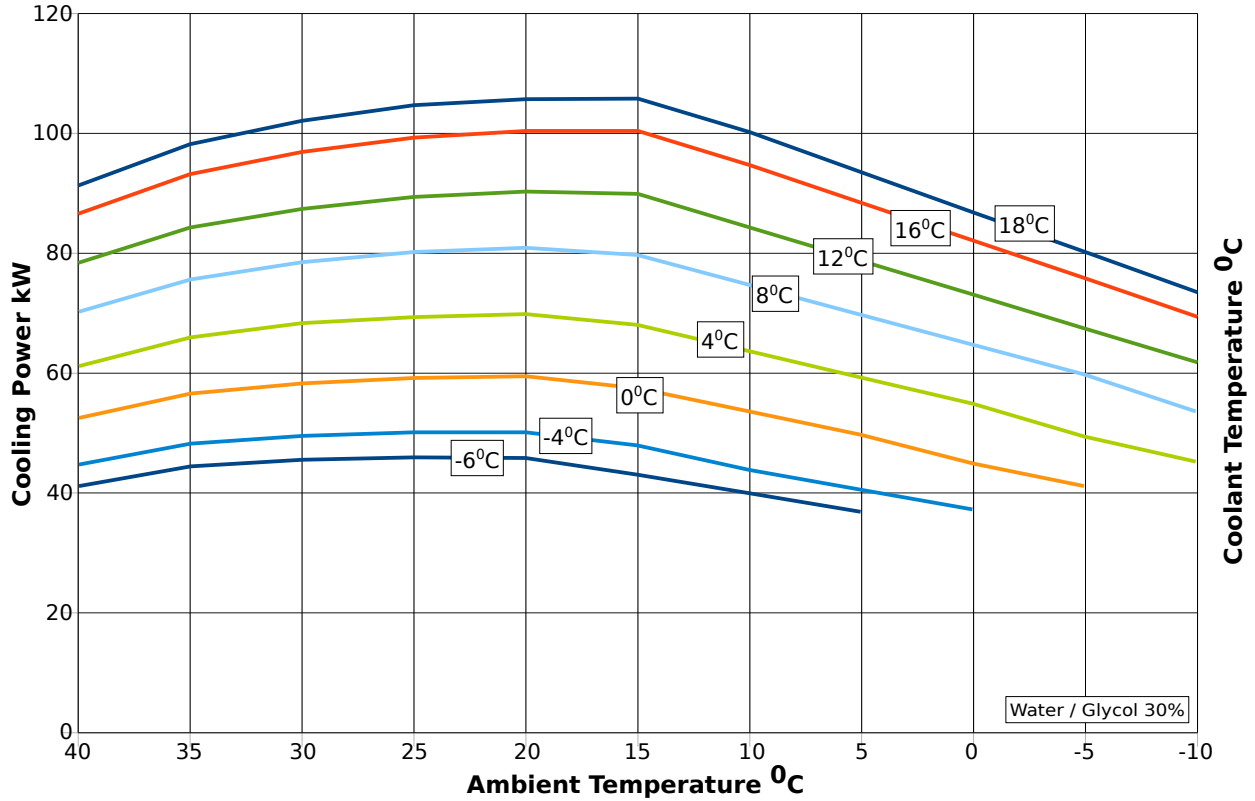

DOMINO SEA 177 Energy Efficiency Rating (EER)

